

PN16 Cast Iron "Y" Strainer

Features

- Flange Mounting PN16 Only
- BS EN 558-1 Series 1

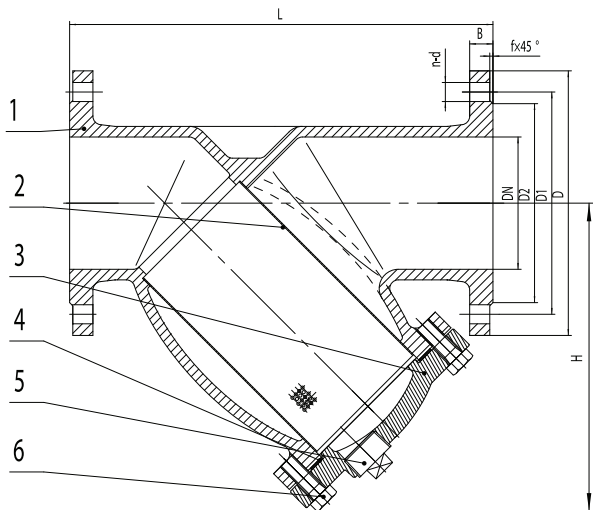

Technical Data

Maximum Pressure 16 Bar
Working Temperature -10°C to +230°C

Dimensions in mm

This data sheet is designed as a guide and should not be regarded as wholly accurate in every detail. We reserve the right to amend the specification of any product without notice.

Pressure/Temperature

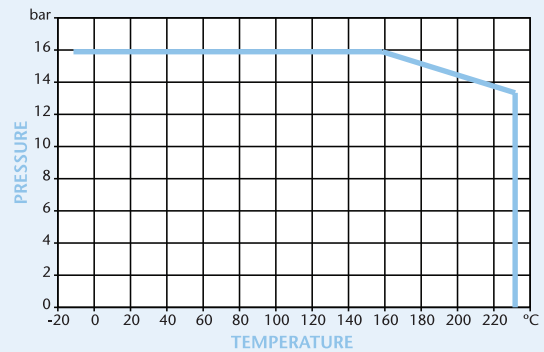

DN	50	65	80	100	125	150	200	250	300
L	230	290	310	350	400	480	600	730	850
D	165	185	200	220	250	285	340	405	460
D1	125	145	160	180	210	240	295	355	410
D2	99	118	132	156	184	211	266	319	370
B	20	20	22	24	26	26	30	32	32
f	3	3	3	3	3	3	3	3	4
n-d	4-19	4-19	8-19	8-19	8-19	8-23	12-23	12-28	12-28
H	156	176	199	240	292	320	399	516	568
Mesh	1.5	1.5	1.5	1.5	1.5	1.5	1.5	1.5	1.5
Kgs	10.1	14	20.3	26.6	39.8	57	97	164	234

N.	Part Name	Materials
1	Body	Cast Iron GG25
2	Screen	Stainless Steel
3	Bonnet	Cast Iron
4	Gasket	Graphite
5	Plug	Cast Brass
6	Bolt	Steel