

Ductile Iron PN16 Flanged Double Check Valve

Features

- Flange mounting PN16 only (EN 1092-2)
- Epoxy coat finish
- Operates in any position
- WRAS Approved as a non-return valve

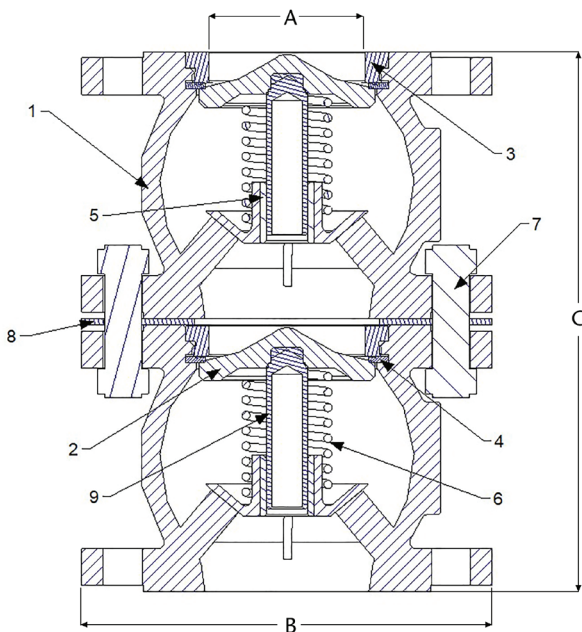

Pressure / Temperature

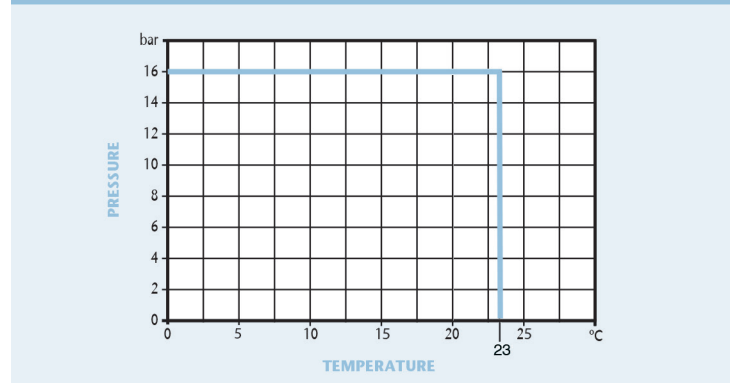

DN	50	65	80	100	125	150	200	250
A	50	65	80	100	125	150	200	250
B	165	185	200	220	250	285	340	405
C	205	245	265	315	405	465	565	693
Kgs	12	16.2	17.2	25	40	60	100	188

N	Part Name	Material
1	Body	Ductile Iron SG 420/12
2	Plunger Top	Delrin 150
3	Sealing Ring	Delrin 150
4	Seal	Nitrile 70 Shore
5	Guide Bush	Cz132 DZR Brass
6	Spring	Stainless Steel Grade 304 S26
7	Studs	Mild Steel (Plated)
8	Gasket	Nitrile 70 Shore
9	Plunger Shaft	Cz132 DZR Brass

Technical Data

Maximum Pressure 16 Bar
 Working Temperature 0°C to +23°C

Dimensions in mm

This data sheet is designed as a guide and should not be regarded as wholly accurate in every detail. We reserve the right to amend the specification of any product without notice.