

## PN82 Stainless Steel Spring Check Valve

### Features

- Screwed BSP Parallel
- Metal Seat
- PTFE Seals
- 316 Stainless Steel Spring



### Pressure / Temperature

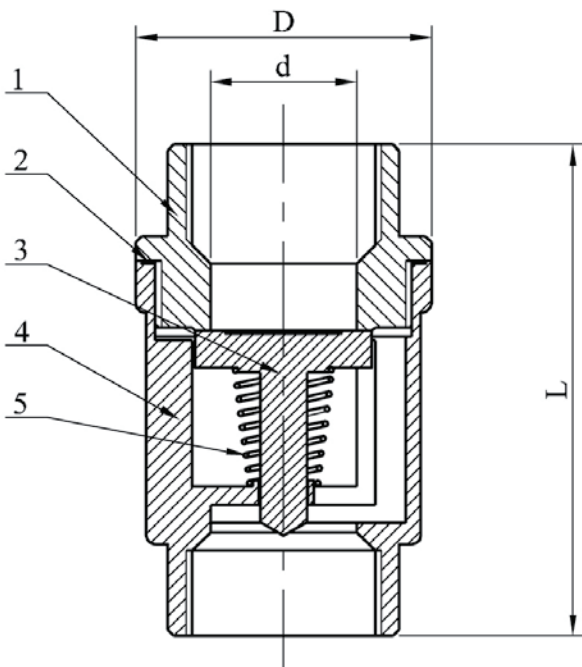
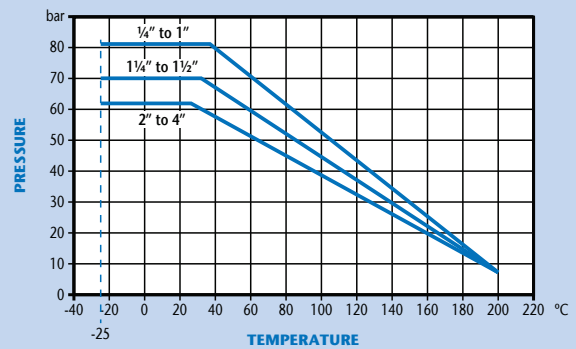

### Technical Data

Max Pressure 82 Bar (1/4"-1") 69 Bar (1 1/4"-1 1/2") 62 Bar (2"-4")  
 Working Temperature -25°C to +200°C

DN	1/4"	3/8"	1/2"	3/4"	1"	1 1/4"	1 1/2"	2"	2 1/2"	3"	4"
d	8	10	15	20	25	30	38	47	61	75	94
D	30.5	30.5	37	42	48	58	70	82	102.5	120	150
L	53	53	56	63	74	81	91	97	118	138	158
Kgs	0.18	0.17	0.21	0.29	0.40	0.65	0.98	1.40	2.44	3.80	6.60

N.	Part Name	Material
1	Cap	CF8M
2	Body Gasket	PTFE
3	Disc	CF8M
4	Body	CF8M
5	Spring	Stainless Steel 316

Dimensions in mm

This data sheet is designed as a guide and should not be regarded as wholly accurate in every detail. We reserve the right to amend the specification of any product without notice.